

LE PROMPT VICAT



hemp  solutions



Application guide
Concrete and hemp mortars



| | |
|--------------------------------------|---------|
| 1. PROFESSIONAL RULES | page 3 |
| 2. DESCRIPTION OF INGREDIENTS | page 3 |
| 2.1 The Hemp Aggregate Building | page 3 |
| 2.2 Prompt natural cement | page 4 |
| 2.3 Tempo | page 4 |
| 2.4 Lime | page 4 |
| 3. APPLICATIONS | page 5 |
| 3.1 Toppings | page 5 |
| 3.2 Timbered walls and formed walls | page 10 |
| 3.3 Roof insulation | page 14 |
| 3.4 Coatings | page 16 |

APPLICATION GUIDE

Concretes and hemp mortars

1. PROFESSIONAL RULES

The application of hemp concrete on the construction site must comply with the professional rules established by the French Association «Building in Hemp» and referred to by the C2P (French Commission for the quality of building product). The company must therefore abide by the hemp construction charter

(www.construction-chanvre.asso.fr/charte-de-la-construction-en-chanvre.fr) and the recommendations of this application guide for the use of Prompt natural cement with validated hemp aggregates, in accordance with the professional rules.

2. DESCRIPTION OF INGREDIENTS

Working with concrete or hemp mortar on the site involves respecting the various elements recommended by Vicat in this application guide.

2.1 THE HEMP AGGREGATE BUILDING

Hemp is a woody annual plant of the cannabaceae family. It develops a stalk 1.50 m to 3.50 m in height in a few months (April to September). Hemp grows very rapidly and produces a large plant mass, thus absorbing and storing a large amount of CO₂ by photosynthesis. The growth of a ton of straw requires the absorption of about 1.7 tons of CO₂ and releases (by volume) as much oxygen. As the plant grows to maturity, one hectare of hemp absorbs 10 to 15 tonnes of CO₂.

Hemp consists of the seed (hempseed), used for food oil and animal feed, and the stem or straw. Straw undergoes transformation to separate the bark fibre from the bark (used for paper pulp, plastic composites and insulation wool) from the boon from the stem wood.

The Building Hemp Aggregate is obtained from the boon by clipping. Its main characteristics are:

- its lightness: apparent volume weight of 100 to 110 kg/m³,
- its insulating capacity: thermal conductivity coefficient of 0.048 W.m⁻¹ K⁻¹,
- its capacity for absorbing water: up to 4 times its weight in water in one minute.

The Building Hemp Aggregate, used by Vicat for characterising the solutions shown in this guide, is manufactured by La Chanvrière de l'Aube (LCDA) and marketed by Technichanvre under the name «C020».

The characteristics of this aggregate are:

- length: 20 to 25 mm,
- width: 1 to 4 mm,
- apparent volume weight: 110 kg/m³,
- colour: very light beige to pale green,
- purity: fibrils and dust < 2%,
- moisture content: < 19 %.



APPLICATION GUIDE

Concretes and hemp mortars

2.2 PROMPT NATURAL CEMENT

Prompt natural cement is a natural hydraulic binder, cooked at low temperature like natural hydraulic lime, following the same traditional process for over 150 years. It is called cement, because, after cooking, the stone does not undergo slaking, as is the case for lime, but simple crushing. Without any mineral or organic addition, its mineralogical composition is identical to that of natural hydraulic lime, but in different proportions.

It benefits from the NF mark: NF P 15-314 (natural prompt cement) and NF P 15-317 (offshore work). Since 13th June 2007, it holds CE marking according to European Technical Approval: ETA-07/0019 - Certificate no. 0679-CPD-0227.

Its main characteristics in the framework **hemp solutions** are:

- its compatibility with lime to which it brings reactivity and hydraulicity (for air-slaked lime),
- its permeability to water vapour in use with the Building Hemp Aggregate or lime,
- its rapid taking and hardening to secure the works at young age,
- its adjustable taking with the use of Tempo, which allows the time required for mixing and application.



2.3 TEMPO

Tempo is a setting retarder made of 100% **food grade** citric acid. This is the most effective retarder for Prompt natural cement. Its use is essential to ensure the handling time required for proper application.

NB: citric acid is biodegradable and not toxic for humans or the environment. However, it is an irritant and can cause burns if it comes into prolonged contact with mucous membranes: it must be used with a few precautions (wearing gloves in particular).

2.4 LIME

Lime comes from low-temperature cooking of pure limestone for air-slaked lime and limestone containing a little silica for natural hydraulic lime. After cooking, they undergo slaking by water to extinguish the quicklime.

Air-slaked lime hardens in contact with air in combination with carbon dioxide.

In the air-slaked part, natural hydraulic lime additionally has more hydraulic properties (hardening

under water), as its name suggests. Mineralogically, these are close to Prompt natural cement.

In the **hemp solutions**, lime is recommended for preparing formulas for coatings. Refer to the manufacturer's data sheet for more information.

3. APPLICATIONS

3.1 TOPPINGS

First, a careful inspection of the supports must be performed to check for the presence of water or rising capillary actions.

 The premises concerned by this application are domestic housing rooms, and the category 5 protective risk equipment subject to maximum P2* mechanical stresses (UPEC classification).

3.1.1 Preparing the supports

The earth-platform topping

A granular fill must be systematically in place to prevent water rising by capillary action and to allow the topping to breathe. It consists of:

- a first layer of 15 cm thickness of size 40/70 coarse gravel,
- a second layer of 10 cm thickness of size 20/40 gravel,

This hardcore must be compacted.

The device is completed by 10 cm diameter drains opening to the outside on walls going in different directions. A hemp concrete drainage device, or a capillary break, is done along very damp walls (Figure 1). The use of hemp concrete screed is prohibited in high humidity areas (with gutter, floor drain, etc.).

The light topping

- The lightness of hemp concrete allows use on an upstairs floor in renovations.
- To prevent transfer of humidity from the topping to the wooden floor, 2 cm of boon with Prompt natural cement sprinkled on it to allow the topping to dry and avoid the laying of a waterproof interface.
- The use of a film that is impermeable to water vapour is not allowed on a wooden floor (example in Figure 3).

**P2: areas where there is no predictable very intense action: static stress limited to 20 kg/cm², but no rolling load other than light objects such as those used in homes.*

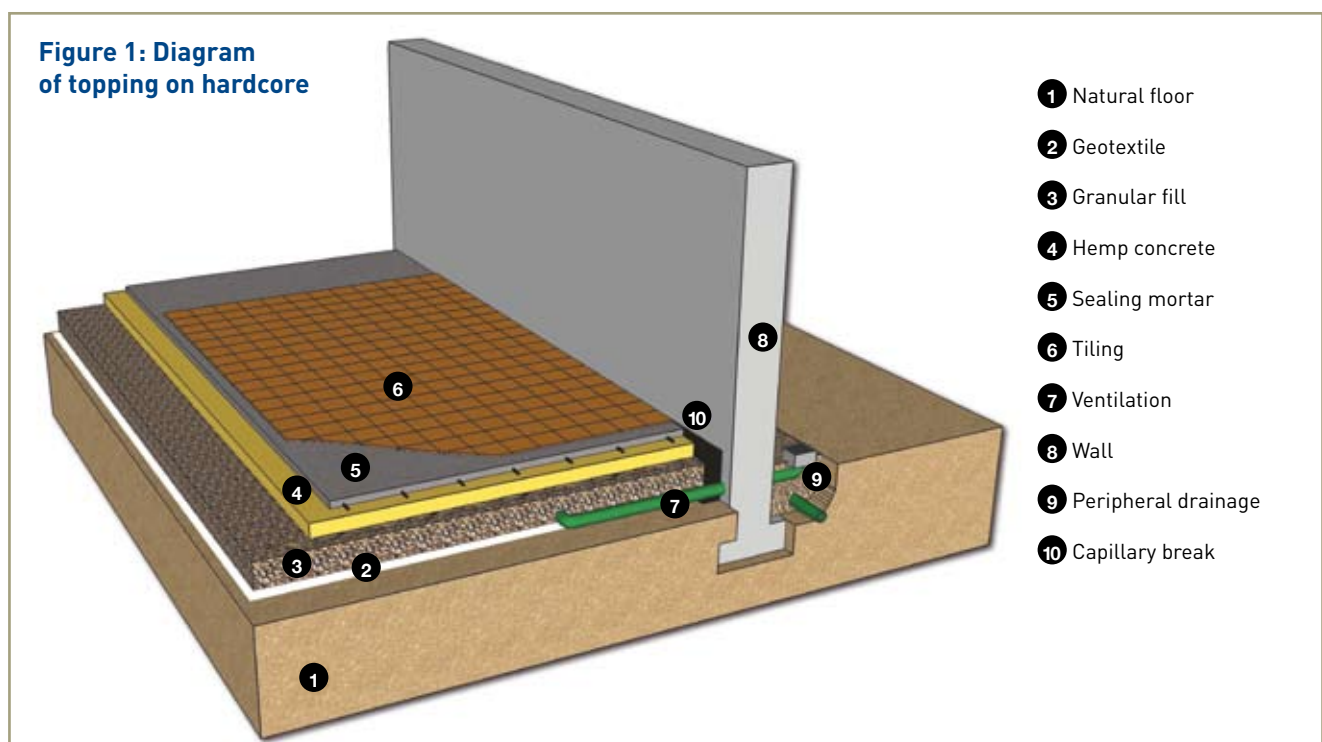

These diagrams are given only as an example. Please call our application advisors for more information on your particular case.

APPLICATION GUIDE

Concretes and hemp mortars

3.1.2 Application

Precautions in use

When applying, the ambient temperature must be 5 to 30°C.

Dosing

| Building Hemp Aggregate | Prompt natural cement | Tempo* | Water** |
|-------------------------|--------------------------|---------|---|
| 100 litres | 30 kg (1 bag + ½ bucket) | 1 flask | 25 litres (mixer) or 27 litres (cement mixer) |

* Dosing of Tempo according to the temperature for working time of about 15 minutes:

If $T^{\circ} < 15^{\circ} C$: 1 flask per bag or 1 cap for 2 litres of Prompt natural cement

If $T^{\circ} > 15^{\circ} C$: 2 flasks per bag or 1 cap per litre of Prompt natural cement

**Adjust to get the desired consistency



Avoid excesses of water, which adversely affect durability.

Mixing methods



MIXING IN THE MIXER

The ingredients are introduced in the following order:

Building Hemp Aggregate + ¾ water + Tempo + Prompt natural cement + remaining water



MIXING IN THE CEMENT MIXER (minimum capacity of 350-400 litres without shaft or central hub if possible)

The ingredients are introduced in the following order:

¾ water + Building Hemp Aggregate + Tempo + Prompt natural cement + remaining water.

Application

The mixture should be homogeneous with a good coating of aggregates by the binder without forming balls. The working time of the mix (or open time) is about 15 minutes when the dosages of Tempo recommended above are followed.

- The first layer is about 5 cm thick, equalised with a rake and then roughly trodden down underfoot.
- The following layers are then equalised with a rake then lightly smoothed or compacted so as not to degrade the thermal performance and acoustics. This application is easier by strips of 1 to 1.2 m wide.

- From the next day, it is possible to walk on the surface. It may be advisable to place planks on the surface for walking on it intensively.

The technical duct must be covered with a minimum thickness of 5 cm.

The minimum thickness of the top surface is 10 cm.



The area must be ventilated for best drying conditions.

3.1.3 Technical characteristics

- Density: 500 to 600 kg/m³ depending on compacting
- Resistance to compression: > 0.3 MPa
- Thermal conductivity: 0.07 W.m⁻¹ K⁻¹ to 0 % humidity

Thermal resistance table

| | | | | | |
|--------------------------------------|------|------|------|------|------|
| Thickness (cm) | 10 | 15 | 20 | 25 | 30 |
| R (m ² KW ⁻¹) | 1,40 | 2,10 | 2,85 | 3,55 | 4,25 |

3.1.4 Consumption

Depending on compacting, for 1 cubic metre of hemp concrete laid, plan about:

- 1,100 to 1,200 litres of Building Hemp Aggregate,
- 330 to 350 kg of Prompt natural cement.

3.1.5 Flooring

Before applying the covering, the surface must be completely set and dry.

This drying depends on the ventilation of the area, the ambient rate of humidity and thickness laid.

Typically, drying takes about from 30 to 60 days for a thickness of 15 cm, depending on the local weather.

APPLICATION GUIDE

Concretes and hemp mortars

Figure 2: Diagram of tiling sealed with sealing mortar on hemp concrete

Following DTU 52.1 and NF P 61-202-1

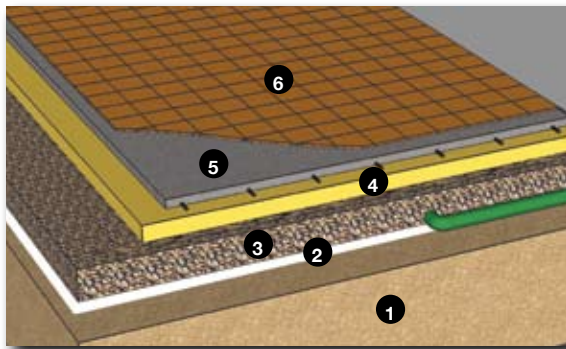

- ❶ Natural floor
- ❷ Geotextile
- ❸ Granular fill
- ❹ Hemp concrete
- ❺ Sealing mortar
- ❻ Tiling

Figure 3: Diagram of tiling glued to the distribution layer on hemp concrete

To standard NF P 14-201-1 and DTU 26.2

- ❶ Load-bearing floor
- ❷ Hemp concrete
- ❸ Distribution layer
- ❹ Glue
- ❺ Tiling

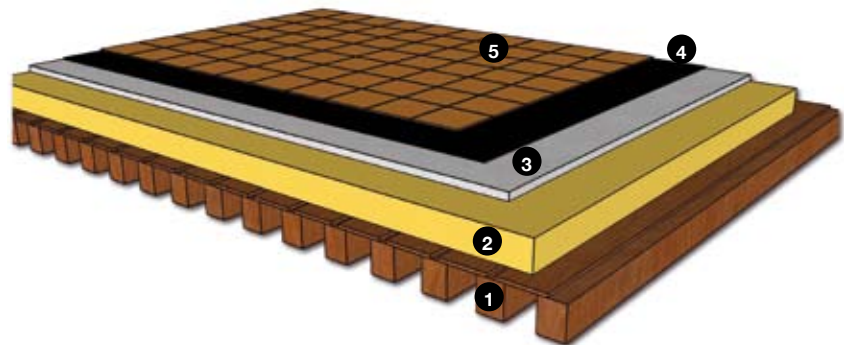
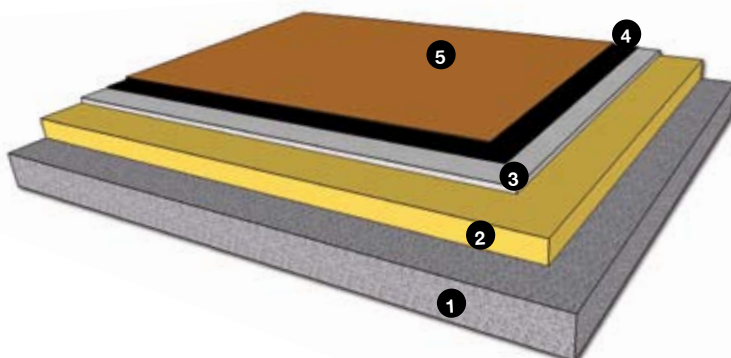

Figure 4: Diagram of flexible covering on the distribution layer (3 to 4 cm thickness) on hemp concrete

DTU 26.2 and standard NF P 14-201-1 (the flexible coating should not be impermeable to water vapour).



- ❶ Hardcore or existing support
- ❷ Hemp concrete
- ❸ Distribution layer
- ❹ Glue
- ❺ Flexible coating

Figure 5: Diagram of floor on joists on particle board over hemp concrete

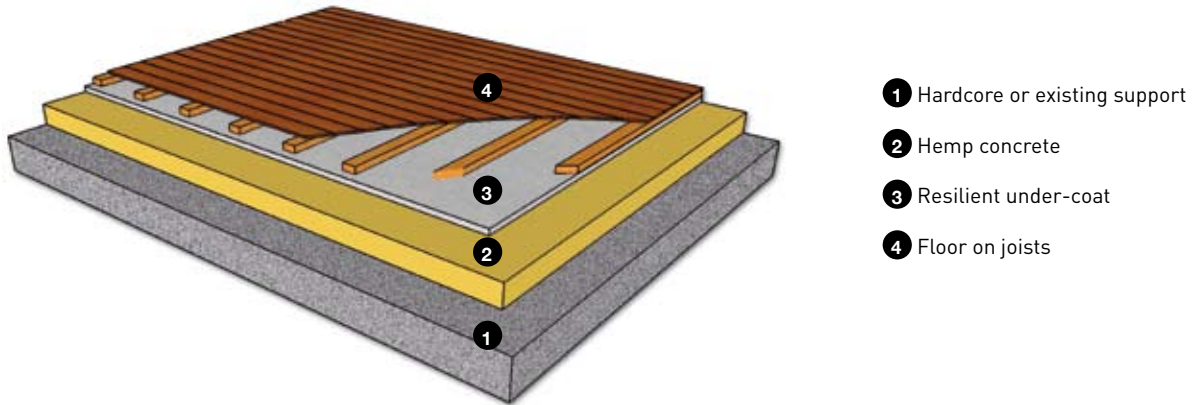

Figure 6: Diagram of floorboards glued to particle board over hemp concrete

Standard NF P 63-203-1, NF P 63-202-1 and DTU 51.2

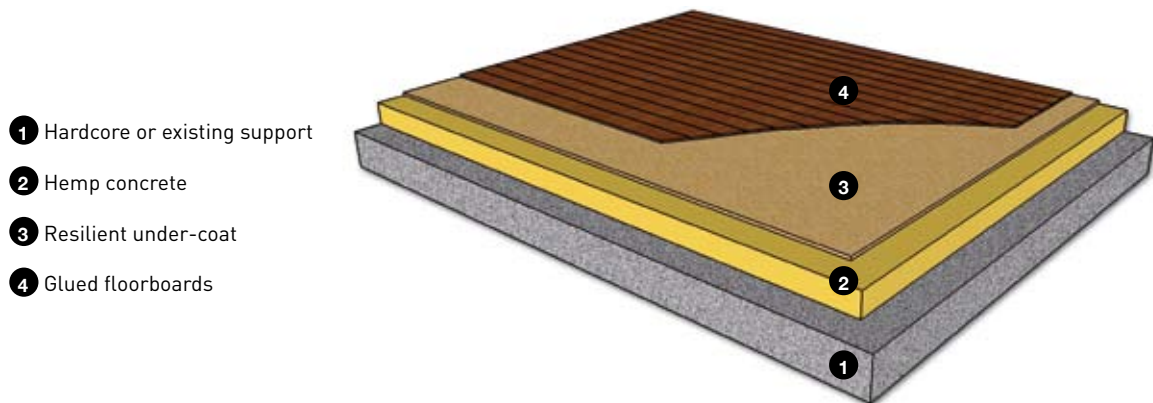
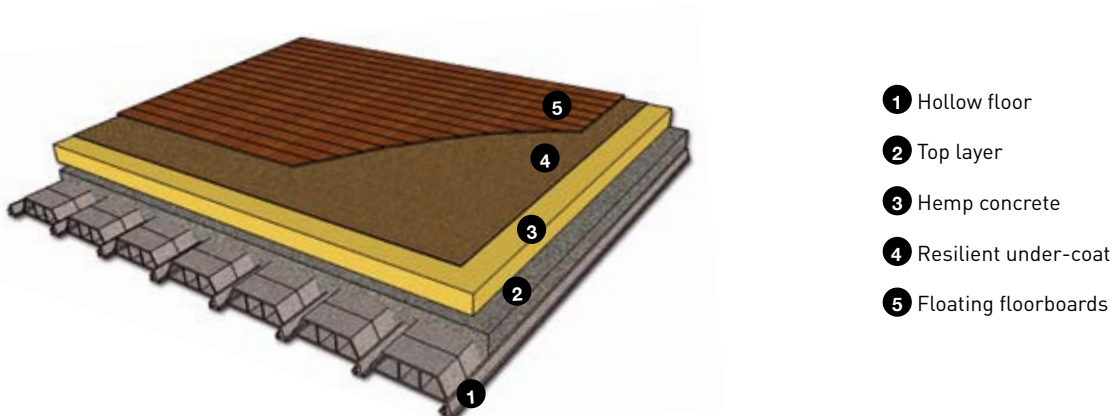

Figure 7: Diagram of floating wooden floor on a resilient thin under-layer on hemp concrete

DTU 51.11 and standard NF P 63-204-1



These diagrams are given only as an example. Please call our application advisors for more information on your particular case.

APPLICATION GUIDE

Concretes and hemp mortars

3.2 TIMBERED WALLS AND FORMED WALLS

-  The buildings concerned by this application are :
- Domestic housing premises up to the 2nd floor (R+2) + attic
 - The protective risk equipment of category 5 limited to the 2nd floor (R+2), except for classified premises (according to the CSTB3567 book) :
 - EB+ humid, common usage premises ;
 - EC very humid premises in a non-aggressive environment.

3.2.1 Preparing the supports

Timbered walls

Nail a lintel to the centre of the timbered wall.
If the timbers are more than 60 cm apart, fix one or several rafters between these timbers.

- On the inside, the pieces of wood must be coated with a minimum thickness of hemp concrete shown below (Figures 9-10).
- The outer surface must be covered with protection (cladding, coating, etc.). Leave a reserve 15-20 mm thickness as necessary for finishing coatings.
- In renovation, when covering is no longer possible, it is recommended to install a secondary structure attached to the framework to ensure the cohesion between this framework and the hemp concrete.

 Do not put apparent hemp concrete on the two sides of an outside wall.

 Do not allow visible wooden frames on the two sides of the wall.

Figure 8: Diagram of wall timbers



These diagrams are given only as an example. Please call our application advisors for more information on your particular case.

Formed walls

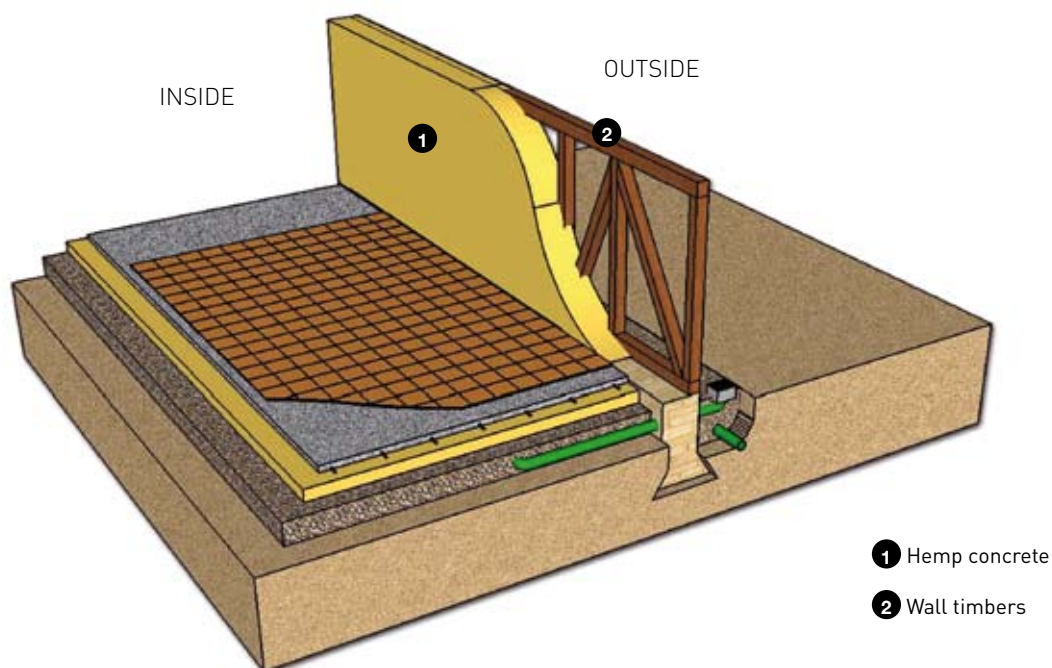
a) Case of existing masonry

- On clean and sound masonry support, first apply a rough-cast: 1 part Prompt natural cement for 2 parts of sand.
- Firstly insert the technical ducts.

b) Case of wooden framework

- Cover the timber frame with a minimum thickness of hemp concrete as defined below (Figures 9-10).
- Firstly insert the technical ducts.

Thickness of wooden structure coating

The covering of the timber depends on their thickness as shown in the diagram below (Figures 9-10). The coating is at least 7 cm. The pieces of wood of more than 8 cm may be left exposed.

Figure 9: Minimum cover thickness (a) depending on the thickness (b) of the piece of wood

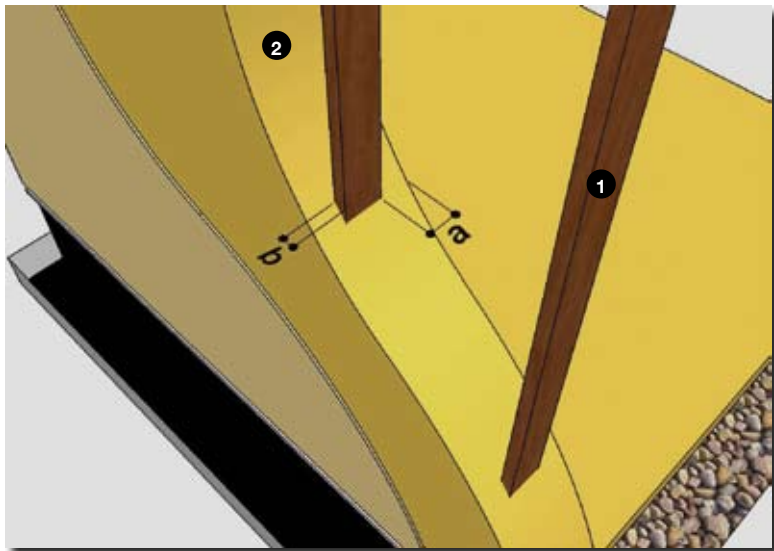

- a : Coating the piece of wood
- b : Thickness of the piece of wood
- 1 Timber frame
- 2 Hemp concrete

Figure 10: Minimum cover thickness (a) depending on the thickness (b) of the piece of wood

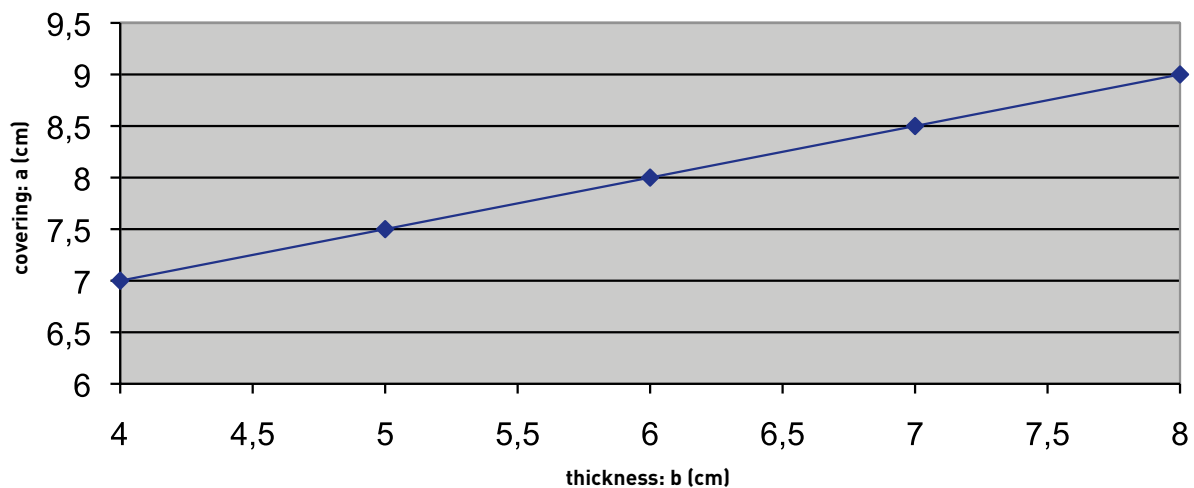

These diagrams are given only as an example. Please call our application advisors for more information on your particular case.

APPLICATION GUIDE

Concretes and hemp mortars

3.2.2 Application

Precautions in use

- Hemp concrete is not to be applied on walls in very damp areas.
- Plan for a capillary break between the basement wall and the hemp concrete.
- Keep a ground clearance of at least 20 cm (Figure 11).
- Hemp concrete walls should not be applied to formed walls in sub-zero temperatures or in high and dry wind. The ambient temperatures usually allowed are 5 to 25° C. Above 25°C, special protection provisions must be applied.

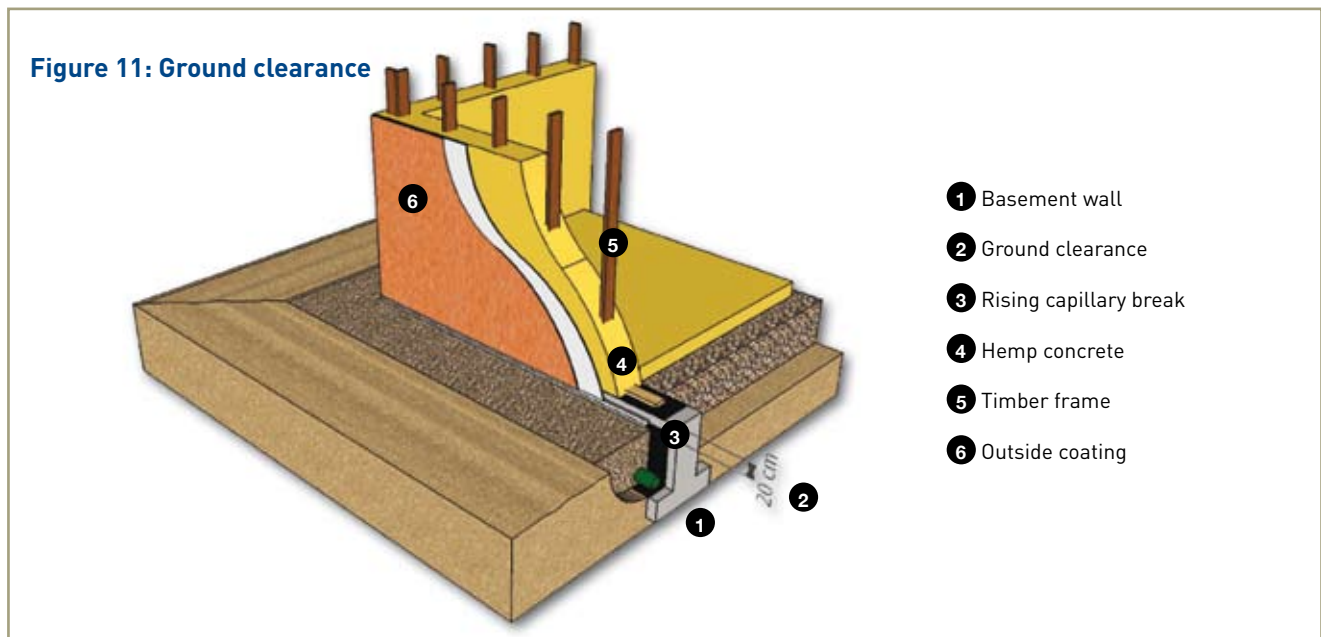

Dosing

| Building Hemp Aggregate | Prompt natural cement | Tempo* | Water** |
|-------------------------|-----------------------|---------|---|
| 100 litres | 25 kg (1 bag) | 1 flask | 24 litres (mixer) or 30 litres (cement mixer) |

**Dosing of Tempo according to the temperature for working time of about 15 minutes:*

If T° < 15° C: 1 flask per bag or 1 cap for 2 litres of Prompt natural cement

If T° > 15° C: 2 flasks per bag or 1 cap per litre of Prompt natural cement

***Adjust to get the desired consistency*



Avoid excesses of water, which adversely affect long lasting.

Mixing methods



MIXING IN THE MIXER

The ingredients are introduced in the following order:
Building Hemp Aggregate + ¾ water + Tempo + Prompt natural cement + remaining water



MIXING IN THE CEMENT MIXER (minimum capacity of 350-400 litres without shaft or central hub if possible)

The ingredients are introduced in the following order:
¾ water + Building Hemp Aggregate + Tempo + Prompt natural cement + remaining water

These diagrams are given only as an example. Please call our application advisors for more information on your particular case.

Application

The mixture should be homogeneous, with a good coating of aggregates by the binder without forming balls.

The working time of the mix (or open time) is about 15 minutes when the dosages of Tempo recommended above are followed.

- Place the form panels according to the thickness of coating and do not forget to leave a reservation of 1.5 to 2 cm for the coating, if the latter shall come to bare wood. The advised height of the form panels is 50 to 80 cm.
- Pour the hemp concrete by successive layers of 10 to 15 cm.
- Tamp down with a "comb" over the whole surface.
- Tread down lightly on the edges of the form panels and the pieces of wood.
- Pour on another layer and so forth.
- As soon as the filling side of the form panel is filled, lift the form panel by sliding it without pulling it away.

- The formwork can be removed as soon as the concrete sets, without waiting, to favour drying as much as possible.

Networks

- The ducts must be separated by 3 cm.
- The ducts must be covered by at least 2 cm of hemp concrete.
- In case of grooving, the grooves must be filled in with the same hemp concrete.

 At each concrete application, even after only a few hours, when the hemp concrete is set, apply a Tempo + Prompt natural cement-based grout before resuming the application phases.

 Vertical joints are to be avoided.

3.2.3 Technical characteristics

- Density: 450 to 550 kg/m³ depending on compacting
- Resistance to compression: > 0.3 MPa
- Thermal conductivity: 0.07 W.m⁻¹ K⁻¹ to 0 % humidity

Thermal resistance table

| | | | | | | | |
|--------------------------------------|------|------|------|------|------|------|------|
| Thickness (cm) | 10 | 15 | 20 | 25 | 30 | 35 | 40 |
| R (m ² KW ⁻¹) | 1,40 | 2,10 | 2,85 | 3,55 | 4,25 | 5,00 | 5,70 |

3.2.4 Consumption

Depending on compacting, for 1 cubic metre of hemp concrete laid, plan for:

- 1,150 to 1,300 litres of Building Hemp Aggregate,
- 280 to 310 kg of Prompt natural cement.

3.2.5 Finishing

The finishing is applied after the complete drying of the hemp concrete. This drying depends on the ventilation of the area, the ambient rate of humidity and thickness laid.

The areas should be well ventilated to favour this drying. Typically, drying takes about 30 to 60 days for a thickness of 15 cm. This drying time can vary more or less depending on local conditions. The permeability to water vapour properties of hemp concrete should not be impeded.

At least one side should be covered with a coating permeable to water vapour.

In case of sheeting finishes, the "rain protection" used must be highly permeable to water vapour (HPV).

In private premises, areas liable to be subject to water splatterings must have the support waterproofed with an appropriate coating.

APPLICATION GUIDE

Concretes and hemp mortars

3.3 ROOF INSULATION



The concerned buildings are domestic housing premises and protective risk equipment of category 5

3.3.1 Preparing the supports

If the underside interior facing is sensitive to humidity, an anti-humidity screen is necessary, by pouring 2 cm boon sprinkled with Prompt natural cement on it.

The sub-surface must be strong enough to bear the application of hemp concrete.

3.3.2 Application

Precautions in use

- Quickly protect this insulation from rain and favour optimum drying.
- Do not apply hemp concrete as roof insulation in sub-zero temperatures or in high and dry wind.

- The ambient temperatures usually allowed are 5 to 30° C.
- To fix formwork, take the weight of the hemp concrete into consideration.

Dosing

| Building Hemp Aggregate | Prompt natural cement | Tempo* | Water** |
|-------------------------|-----------------------|---------|-----------|
| 200 litres | 25 kg (1 bag) | 1 flask | 44 litres |

**Dosing of Tempo according to the temperature for working time of about 15 minutes:*

If T° < 15° C: 1 flask per bag or 1 cap for 2 litres of Prompt natural cement

If T° > 15° C: 2 flasks per bag or 1 cap per litre of Prompt natural cement

***Adjust to get the desired consistency*



Avoid excesses of water, which adversely affect long lasting.

Mixing methods



MIXING IN THE MIXER

The ingredients are introduced in the following order:
Building Hemp Aggregate + ¾ water + Tempo + Prompt natural cement + remaining water



MIXING IN THE CEMENT MIXER (minimum capacity of 350-400 litres without shaft or central hub if possible)

The ingredients are introduced in the following order:
¾ water + Building Hemp Aggregate + Tempo + Prompt natural cement + remaining water

Application

The mixture should be homogeneous with a good coating of Building Hemp Aggregate by the binder without forming balls.

The working time of the mix (or open time) is about 15 minutes when the dosages of Tempo recommended above are followed.

- Pour the mixture between the joists and spreading it with a rake without packing down.
- Put in a thickness of 1 to 2 cm above the final thickness, then smooth off or pack down lightly to correct it.

- Leave a gap of at least 1 to 2 cm between the hemp concrete and tops of the rafters to allow good ventilation, needed for drying.
- At least one side should be covered with a coating permeable to water vapour. (Figures 12-13).

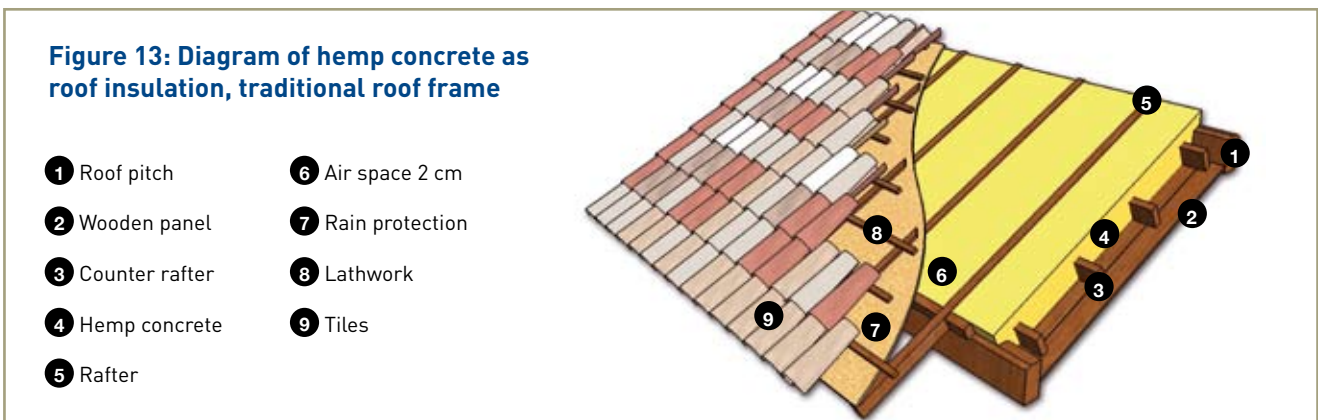
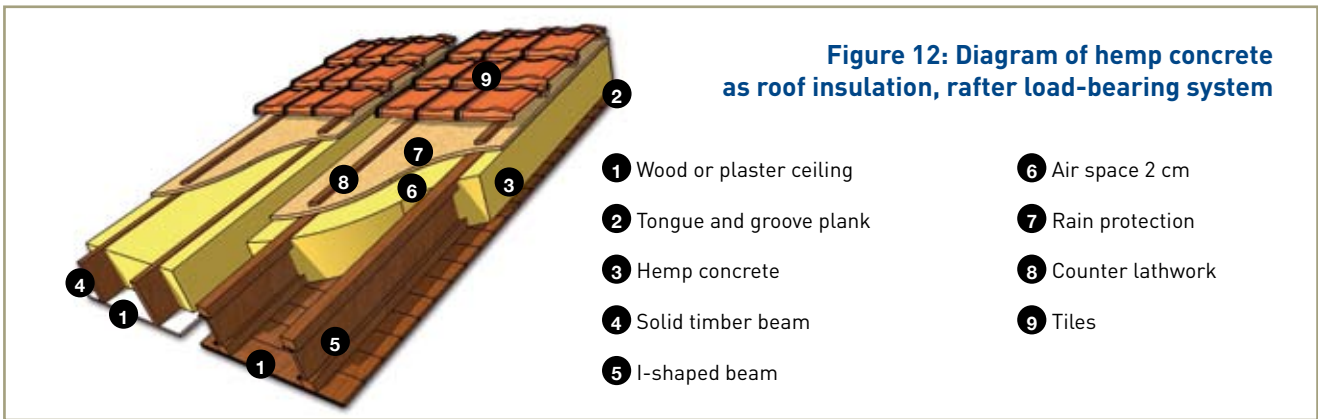

3.3.3 Technical characteristics

- Density: 280 to 320 per m³ depending on compacting
- Resistance to compression: > 0.3 MPa
- Thermal conductivity: 0.07 W.m⁻¹ K⁻¹ to 0 % humidity

Thermal resistance table

| Thickness (cm) | 10 | 15 | 20 | 25 | 30 |
|--------------------------------------|------|------|------|------|------|
| R (m ² KW ⁻¹) | 2,00 | 3,00 | 4,00 | 5,00 | 6,00 |

3.3.4 Consumption

Depending on compacting, for 1 cubic metre of hemp concrete laid, plan for:

- 1,000 to 1,100 litres of Building Hemp Aggregate,
- 110 to 150 kg of Prompt natural cement.

3.3.5 Roofing

Depending on the chosen type of roofing, refer to the local professional rules.

APPLICATION GUIDE

Concretes and hemp mortars



3.4 COATINGS

 The concerned buildings are domestic housing premises and protective risk equipment of category 5, except for classified premises :

- EB+ humid, common usage premises ;
- EC very humid premises in a non-aggressive environment (CSTB3567 book).

3.4.1 Preparing the supports

● On a sound, clean and dust-free support, dampen and apply a Prompt natural cement rough-cast: 1 part of Prompt natural cement for 2 parts of 0/4 sand. A few hours after, the hemp coating may be applied.

● On existing coating, check its adhesion.

-  - If it does not adhere enough, remove it and clean the support.
- If it is too smooth, roughen it.

The support should not show any traces of humidity or rising damp.

3.4.2 Application

Precautions in use

- Hemp coatings should not be applied in sub-zero temperatures or in high and dry wind. The ambient temperatures usually allowed are 5 to 30° C.
- Outdoors, leave a 20 cm ground clearance.

 Hemp coatings should not be applied in very damp areas.

Dosing for the coating body mixed in a cement mixer or in the mixer

| Building Hemp Aggregate | Lime CL90 or NHL2 | Prompt natural cement | Sand (0-2, graded and washed) Tempo* | Water** |
|-------------------------|-------------------|-----------------------|--------------------------------------|-------------------|
| 100 litres | 45 litres | 12 litres | 10 litres | 1 flask 55 litres |

**Dosing of Tempo (if necessary) depending on the temperature:
If $T^{\circ} < 15^{\circ} C$: 1 flask per bag or 1 cap for 2 litres of Prompt natural cement
If $T^{\circ} > 15^{\circ} C$: 2 flasks per bag or 1 cap per litre of Prompt natural cement*

***Adjust to get the desired consistency.*

 Avoid excesses of water, which adversely affect long lasting.

Mixing methods



MIX IN THE MIXER ALL AT ONCE WITH CL90 OR NHL2

The ingredients are introduced in the following order:

- Building Hemp Aggregate + 1/3 of the mixing water + lime + sand + the remainder of the water, and wait until the mixture is homogeneous.
- Add the Tempo + Prompt natural cement + the remaining water to adjust the proper handling: greasy and soft texture.



MIX IN THE MIXER IN TWO SESSIONS WITH CL90

This method allows for a more flexible and easier to implement mixture and a better-controlled mixing time more suited to the pace of application.

- Firstly, the day before if possible, mix: Building Hemp Aggregate + 1/3 mixing water + lime + sand + the remaining water. Mix until you get an even mixture.
- Store this mixture in a mixing tub for a rest time.
- The next day or a few hours later, mix again and add Prompt natural cement with or without Tempo (in this case the setting will be faster). Correct the texture by adding water if necessary and then apply to the support.



MIX IN THE CEMENT MIXER ALL AT ONCE WITH CL90 OR NHL2

The ingredients are introduced in the following order:

- ¾ water + sand + lime. Wait for the grout to become constant.
- Add Building Hemp Aggregate and wait 10 to 15 minutes until the consistency is even.
- Add the Tempo + Prompt natural cement + the remaining water to adjust the proper handling: greasy and soft texture.



MIX IN THE CEMENT MIXER IN TWO SESSIONS WITH CL90

This method allows for a more flexible and easier to implement mixture and a better-controlled mixing time more suited to the pace of application.

- Firstly, the day before if possible, mix: ¾ water + sand + lime. Wait for the grout to become constant, and then add the Building Hemp Aggregate. Mix until you get an even mixture.
- Store this mixture in a mixing tub for a rest time.
- The next day or a few hours later, mix again and add Prompt natural cement with or without Tempo (in this case the setting will be faster). Correct the texture by adding water if necessary and then apply to the support.



Job done by - SARL INTERIEUR CHANVRE - 71240 Etrigny France

Application

The mixture should be homogeneous with a good coating of Building Hemp Aggregate by the binder without forming balls.

The working time of the final mix (or open time) is 20 to 30 minutes depending on the temperature.

Apply the coating on the support, with a trowel, a mortar board, or by hand (gloves required) by successive passes of 3 to 4 cm with no waiting time, wet on wet. It

is not necessary to wait until the beginning of setting to apply the next layer. A total thickness, up to 12 cm, is feasible in a single layer, with this technique, without any waiting time between different applications. Smooth out the last application.

Indoors, it is possible to leave the coating visible except in damp rooms.

Outdoors, the coating must be protected by a finishing layer or siding.

APPLICATION GUIDE

Concretes and hemp mortars

3.4.3 Technical characteristics

- Density: 800 à 860 kg per m³ depending on tightness
- Resistance to compression: > 0.3 MPa
- Thermal conductivity: 0.09 W.m⁻¹ K⁻¹ to 0 % humidity

Thermal resistance table

| | | | | |
|--------------------------------------|------|------|------|------|
| Thickness (cm) | 5 | 10 | 15 | 20 |
| R (m ² KW ⁻¹) | 0,55 | 1,10 | 1,65 | 2,20 |

3.4.4 Consumption

Depending on compacting, for 1 cubic metre of hemp concrete laid, plan for:

- 1,000 to 1,100 litres of Building Hemp Aggregate,
- 110 to 130 kg of Prompt natural cement,
- 210 to 240 kg of lime,
- 150 to 170 kg of sand.

3.4.5 Finishing

The finishings must be permeable to water vapour.

A tighter hemp mortar finish, on a few millimetres thickness can be applied on the still fresh coating in dose:

| Building Hemp Aggregate | Lime CL90 or NHL2 | Fine sand (<1 mm) | Water* |
|-------------------------|-------------------|-------------------|-----------|
| 100 litres | 75 litres | 45 litres | 65 litres |

**Adjust to get the desired consistency*



Avoid excesses of water, which adversely affect long lasting.

Other finishings are applied after the complete drying of the hemp coating.

This drying depends on the ventilation of the areas, the ambient rate of humidity and thickness.

- The areas should be well ventilated to favour drying. Typically, drying takes at least 2 to 3 months for a thickness of 10 cm. A coating of air-slaked lime, a stucco type film coating or semi-thick coating can be applied.
- Outdoors, a lime finishing or cladding is required.

hemp **solutions**

ECO-CONSTRUCTION / ECO-RENOVATION

HEMP CONCRETES AND MORTARS FOR THE BUILDING

HIGH-PERFORMANCE SOLUTIONS

- ▶ High thermal resistance and good inertia (*summer comfort*)
- ▶ Good hygrometric behaviour
- ▶ Good fire behaviour (*reaction and resistance*)

SUSTAINABLE SOLUTIONS

- ▶ 100% natural
- ▶ Completely recyclable
- ▶ CO₂ storage

"COMFORT" SOLUTIONS

- ▶ Thermal comfort in all seasons (*warm walls in winter*)
- ▶ Acoustical comfort
- ▶ Visual comfort (*lime, plaster or clay finishes*)
- ▶ Inside air quality (*No VOCs and humidity controlled*)



INSULATION OF WALLS



INSULATION OF FLOORS



INSULATION AND DECORATIVE FILLER COMPOUNDS



INSULATION OF ROOFS

Constructive solutions with **100% natural concrete** conforming to the Professional Rules of Hemp-based Constructions

VICAT - COMMERCIAL CEMENT MANAGEMENT

Tél. 04 74 18 40 25

cimentnaturel@vicat.fr

WWW.VICAT.FR





Tel.: 0 800 505 38 02

www.ionicbuildingsupplies.co.uk

VICAT

International Trading

4, Quai Papacino - 06300 NICE - France

Tel: +33 (0)4 92 00 18 80 Fax: +33 (0)4 92 00 18 89

vit.export@vicat.fr - WWW.VICAT.FR

